

Table of Contents

24 Hour Roadside Assistance

Commitment to Service	2
When does coverage start & end?	2
Who is covered?	2
What is covered?	2
How do I use Roadside Assistance?	2
What is not covered?	2

Instructions for transporters

Use a flatbed only	3
Preparing the vehicle for transporting	3
Activating Tow Mode	3
Attaching the recovery eye	4
Securing the wheels	4

24 Hour Roadside Assistance

Commitment to Service

Tesla Motors is committed to providing customers with the best level of service possible. To minimize any unforeseen inconvenience, Roadside Assistance is available to you, 24 hours a day, 365 days a year, throughout the continental United States and Canada.

When does coverage start & end?

Roadside Assistance benefits are provided for all Tesla vehicles from the date the vehicle is delivered to the first retail purchaser, put into use, leased, or registered as a company car or demonstrator, whichever is earlier. Coverage extends through the bumper-to-bumper portion of the New Vehicle Limited Warranty Period of 36 months, or 36,000 miles (60,000 kms), whichever occurs first.

Who is covered?

All Tesla vehicles, with the authorization of the owner. These services are transferable with the resale of the vehicle for the time remaining on the original Tesla New Vehicle Limited Warranty coverage period, provided Tesla Motors has been notified of the change of ownership (either in-person at a Tesla Store or by mailing the Change of Ownership form provided in the New Vehicle Limited Warranty document).

What is covered?

Services include emergency services such as flat tire assistance and vehicle recovery

services. For all vehicles that experience a flat tire, your vehicle is transported, free of charge, to the nearest Tesla Store or to a local tire center, provided it is located within 25 miles (40 kms). If the vehicle needs to be transported over 25 miles (40 kms), the owner is responsible for transportation costs.

If necessary, you can choose to have the Roadside Assistance representative assist with your vehicle's tire sealant kit and provide tire inflation to allow you to drive the vehicle to the nearest tire repair facility.

All vehicles experiencing a malfunction, collision, or flat tire are eligible for transportation services. Transportation services are provided free-of-charge to the nearest Tesla Store, or to your home, if the Tesla Store or your home is located within 25 miles (40 kms) of the incident. Malfunctions determined to be caused by abuse or negligence, as described in the New Vehicle Limited Warranty, will not be covered.

The vehicle must always be transported using a flatbed trailer. It is your responsibility to provide vehicle transporters with the instructions printed in this booklet.

How do I use Roadside Assistance?

Simply call 866-99TESLA (866-998-3752) and advise the representative of the vehicle identification number (VIN), license plate number, mileage, your location, and the nature of the problem. The VIN is on the upper dashboard on the driver's side of your vehicle and is visible through the windshield.

You may be required to sign a receipt to acknowledge that Roadside Assistance services have been provided.

For your convenience, a wallet card is provided in your owners package.

What is not covered?

Any charges for the replacement of non-warranty items or additional services will be your responsibility at the time of service. Roadside Assistance is not a warranty and is not provided under any Tesla warranty, but is a service provided to you to minimize unforeseen vehicle operation inconvenience. Potential liability is expressly limited to the cost of the listed benefits and does not extend to incidental or consequential damages such as loss of use inconvenience, loss of pay, or commercial loss. Roadside Assistance benefits exclude any costs related to repairs, parts replacement, labor, etc. which are incurred as a result of accident/collision, vehicle abuse, racing, vandalism or other items not covered by the New Vehicle Limited Warranty. Also excluded are services for snow tires, mounting or demounting of snow chains, and any fines, fees or taxes which are associated with impound towing as a result of actual or alleged violation of any laws or regulations.

Instructions for transporters

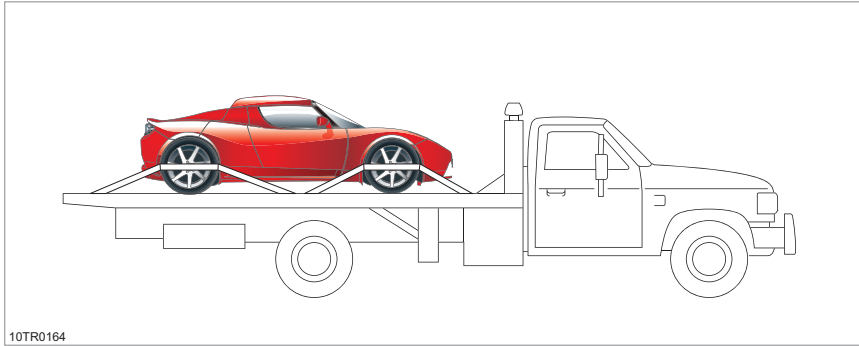

10TR0164

Use a flatbed only

The only approved method of transporting your vehicle is using a flatbed trailer or transporter. Towing the vehicle will cause serious damage to the power train. This damage will not be covered by the New Vehicle Limited Warranty.

 Caution: Serious damage to the vehicle and transmission can occur if the vehicle is towed with the wheels on the ground or on a suspended lift.

 Caution: The transmission lock will only retract when the vehicle is in Tow Mode or when the electrical systems are functional, the key is in the ON position and the Neutral gear is engaged.

Preparing the vehicle for transporting

Before pulling the vehicle onto a flatbed trailer or transporter, follow these steps:

- activate Tow Mode to disengage the transmission lock, or turn the key to the ON position and select the Neutral gear position
- attach the vehicle recovery eye

Activating Tow Mode

Tow Mode disengages the transmission lock so the vehicle can roll freely.

Note: In the unlikely situation in which electrical systems are not functioning and

therefore Tow Mode can not be activated, wheeled dollies or skid pads must be used.

1. Turn OFF the vehicle and apply the hand brake. The Touch Screen displays the main Parked screen.

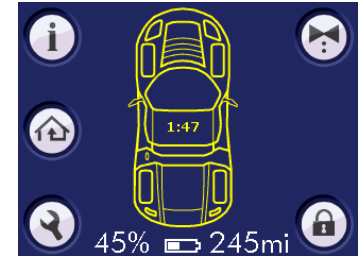

2. Touch  to display the first settings screen.

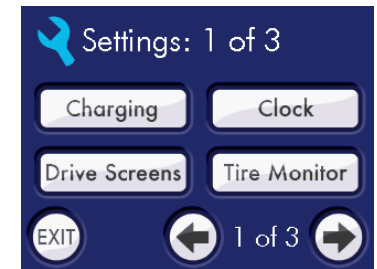

3. Touch  to display the third settings screen.

Instructions for transporters



4. Touch **Tow Mode**, then touch **OK** to confirm.

The Touch Screen displays the following message indicating that the vehicle is in Tow Mode.

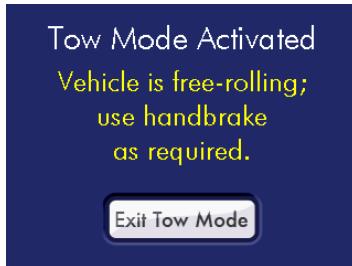

5. Release the hand brake when appropriate.

Note: Although Tow Mode is activated, the steering column lock will be engaged. To disengage the steering column, turn the key to the ACC position. If it is difficult to turn the key, move the steering wheel slightly.

Caution: The car can roll freely in Tow Mode. If the vehicle is not on a flat

surface, do not release the hand brake until the vehicle is ready to be pulled.

Note: You can not start or charge the vehicle until you exit Tow Mode.

Attaching the recovery eye

A vehicle recovery eye can be attached to the front of the vehicle to allow the vehicle to be pulled onto a transporter in situations when the vehicle can roll freely.

Caution: NEVER tow the vehicle using the vehicle recovery eye. Doing so can cause serious, even fatal injury to other motorists and can also cause significant damage to your vehicle.

1. Retrieve the recovery eye from the tool kit located in the trunk.
2. Using the screwdriver (also supplied in the toolkit), remove the plug from the recovery eye mounting point behind the front grill. If a license plate has been installed on the front of the vehicle, it must be removed to access the recovery eye.
3. Insert the recovery eye through the hole in the front grill and screw into the mounting point. Ensure the recovery eye is fully tightened.

After use, remove the recovery eye and return it to the tool kit. Insert the plug back into the mounting point to prevent dirt from entering.

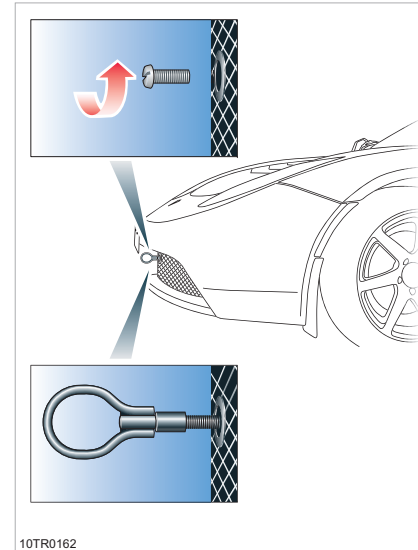

Securing the wheels

When the vehicle has been pulled onto the transporter or trailer, use chocks and tie down straps to secure the wheels. To avoid damage:

- Ensure that metal parts on tie down straps do not contact the vehicle's painted surfaces or the face of any wheels.
- Do not place straps over or through the vehicle's body panels.

Caution: Attaching straps to the chassis, suspension or other parts of the body can damage the vehicle.